



Instruction for use

MK-dent high speed Turbine

Version: 2023-06-20-RevE

CE 0123

Table of Contents

1	About this instruction for use	4
1.1	Explanation of warnings	4
1.2	Compliance	4
2	Intended purpose.....	5
2.1	Intended use.....	5
2.2	Indications	5
2.3	Contraindications	5
2.4	Intended patient groups.....	5
2.5	Intended user	5
2.6	User environment	5
3	Safety and Requirements	6
3.1	General safety regulations	6
3.2	Reporting obligation.....	6
3.3	Side effects	6
3.4	Risk patient groups.....	6
4	Product description.....	7
4.1	Description	7
4.2	Combination with other products	8
4.3	Product components	8
4.4	Scope of delivery	8
4.5	Required materials that are not included	9
4.6	Configurations	9
5	Accessories, tools, consumables and spare parts	10
5.1	Accessories	10
5.2	Tools.....	11
5.3	Consumables	12
5.4	Spare parts	12
6	Installation	12
6.1	Requirements for the environment	12
6.2	Unpacking.....	12
6.3	Assembly	12
6.4	Preparation for use.....	13
6.4.1	Check and setting of the compressed air	13
6.4.2	Connection to the coupling system	14
6.4.2.1	Connecting the instrument – Turbine with direct connection.....	14
6.4.2.2	Connecting the instrument – Turbine with coupling connection	14
6.5	Putting into service and operation	15
6.5.1	Before use.....	15
6.5.2	Check of correct operation	15

6.5.3	Testing the water quantity	15
6.5.4	Insertion of rotating instruments	15
7	Treatment	17
7.1	Patient, operator and assistant protection	17
7.2	Removing rotating instruments.....	17
8	Reprocessing according to ISO 17664-1.....	18
8.1	Processing at the location of use.....	18
8.1.1	Preparation for cleaning	19
8.1.2	Manual pre-cleaning of the spray nozzle.....	19
8.1.3	Manual pre-cleaning of the instrument.....	20
8.1.4	Manual pre-cleaning of the glass rod of turbines with light.....	21
8.2	Manual pre-cleaning	21
8.2.1	Manual cleaning	21
8.2.2	Manual disinfection, rinsing and drying	21
8.3	Automatic cleaning.....	22
8.3.1	Cleaning, disinfection and rinsing.....	22
8.3.2	Mechanical drying	22
8.3.3	Maintenance, checks and testing	22
8.4	Sterilization in an autoclave	23
8.4.1	Wrapping.....	23
8.4.2	Sterilization in a steam sterilizer according to EN 13060 / EN ISO 17665-1	23
8.4.3	Sterilization parameters	24
8.4.4	After sterilization	24
8.5	Storage	24
9	Maintenance	25
9.1	Regular maintenance and checks	25
9.2	Cleaning in case of problems.....	25
10	Disposal.....	25
11	Troubleshooting.....	26
12	Repair.....	26
13	Technical data	27
14	Explanation of symbols	28
15	Warranty	29

1 About this instruction for use

This Instruction Manual applies to all MK-dent turbines (see Chapter 4 **Product description**).

All products listed in this document are intended exclusively for dental medical treatments in the field of dentistry. Any kind of use for unrelated purposes or modifications of the product are prohibited and can cause danger. All products referred to in this document may be used exclusively by skilled users according to Chapter 2.5 **Intended operator profile** within the scope of the intended use defined for each of them and in observation of the Instruction Manual.

1.1 Explanation of warnings

This Instruction Manual is meant to explain the safe and effective operation of the described product. Before you use the product, you have to read this Instruction Manual, and notice and strictly observe all safety information and warnings. Pay particular attention to all information and procedures that are described in chapter 3 **Safety and requirements**.

This Instruction Manual is part of the product and must be kept within reach of the product so that they are accessible at any time.

To prevent personal injuries and property damages, please notice the warnings and safety information contained in this document. These are specially marked:



WARNING

A WARNING alerts you to a potentially serious outcome, unwanted result or safety risk. Failure to observe a warning can result in death or serious injury of the user or patient.



CAUTION

CAUTION alerts you to situations requiring particular care for the safe and effective use of the product. Disregard for a precautionary measure can result in minor or moderately severe personal injuries or damages to the product or other property and potentially cause a remote risk of serious injuries and/or environmental pollution.

NOTICE

NOTICE

This identifies special tips, for example, as help to the user or for the improvement of a work process.

1.2 Compliance

This medical device fulfils the requirements of Directive 93/42/EEC.

CE 0123

This product complies with the following international standards:

- ISO 14971 Application of risk management to medical devices
- IEC 62366-1 Application of usability engineering to medical devices

If you have further questions on the applicable national or international standards, please direct them to the manufacturer:



MK-dent GmbH
Marie-Curie-Str. 2
22941 Bargteheide
Germany

2 Intended purpose

2.1 Intended use

High-speed contra angled handpieces (**turbines**, max. 250,000 – max. 420,000 rpm): air-powered drives for rotating instruments for the removal of carious material, for the preparation of cavities and crowns and for the removal of fillings.

2.2 Indications

Turbines are motors for rotating instruments used for the removal of caries, preparation of cavities and crowns and for the removal of fillings.

2.3 Contraindications

No contraindications are known to date.

2.4 Intended patient groups

Patients in dental treatment for the removal of caries material, preparation of cavities and crowns and for the removal of fillings. The decision to use a high-speed contra angled handpiece, however, is within the sole responsibility of the dentist.

2.5 Intended user

MK-dent turbines are intended exclusively for use by accredited dentists.

2.6 User environment

Application takes place in dental offices or dental medical centres.

3 Safety and Requirements

3.1 General safety regulations



WARNING

- This product is delivered in unsterilised condition. Sterilise it in the autoclave before initial use.
- Sterilization must be performed before initial use and after each use on a patient in order to prevent direct cross infections.
- This product may be used only by qualified personnel and only for dental treatment.
- Never disassemble or modify this product.
- In case of problems, please do not attempt repair it on your own. Contact your dealer for the repair.
- Please do not use the product if the performance of the product deteriorates or in case of malfunctions.
- Do not use this product if it has not been serviced properly.
- Observe the precautionary measures for use in order to ensure correct and safe functioning.



CAUTION

- Before initial use and after each treatment, the instrument and accessories must be processed according to the Instruction Manual
- The product may be used exclusively in the field of dentistry with a dental treatment unit, which has a CE-marking or is otherwise certified/approved according to the valid national legal regulations, and which is provided with an appropriate water and compressed air supply in compliance with the applicable standards.
- Test for proper functioning before each use and inspect the instrument visually for external damages.
- A low quantity of spray water can result in the overheating of the instrument and corresponding injuries.

3.2 Reporting obligation

In the event of a serious deterioration in the patient's health during the use of this product, please report this to your specialised dealer or to us as the manufacturer, as well as to the BfArM (Federal Institute for Drugs and Medical Devices).

You can find our contact details in this Instruction for use. We will also inform you of the contact details of the named body upon request.

3.3 Side effects

No side effects are known to date.

3.4 Risk patient groups

No risk patient groups are known to date.

4 Product description

4.1 Description

The MK-dent turbines are available in the following variants: PRIME LINE, CLASSIC LINE, ECO LINE, BASIC LINE

The compact shape of the turbine makes switching between treatment units easy and requires only little space for storage.

The quick coupling system enables easy swapping of the turbines and instant use. No complicated installation is needed, which allows for simple integration in your treatment system.

Powered by compressed air from the treatment unit, the turbine has no effect on other medical devices nor is it influenced by electromagnetic waves.

Article no.	Standard head	Small head	Mini head	With light	Without light	2-hole connection	4-hole connection	5-hole connection	Quick coupling system
HB12	X	-	-	-	X	-	X	-	-
HB14	-	-	X	-	X	-	X	-	-
HB15L	X	-	-	X	-	-	-	X	-
HB16L	-	-	X	X	-	-	-	X	-
HB21K	X	-	-	-	X	-	-	-	X
HB21KL	X	-	-	X	-	-	-	-	X
HB23K	-	-	X	-	X	-	-	-	X
HB23KL	-	-	X	X	-	-	-	-	X
HE11	X	-	-	-	X	X	-	-	-
HE12	X	-	-	-	X	-	X	-	-
HE14	-	-	X	-	X	-	X	-	-
HE15L	X	-	-	X	-	-	-	X	-
HE16L	-	-	X	X	-	-	-	X	-
HE17	X	-	-	-	X	-	X	-	-
HE17B	X	-	-	-	X	X	-	-	-
HE18	-	X	-	-	X	-	X	-	-
HE20K	X	-	-	-	X	-	-	-	X
HE20KL	X	-	-	X	-	-	-	-	X
HE21K	X	-	-	-	X	-	-	-	X
HE21KL	X	-	-	X	-	-	-	-	X
HE21N	X	-	-	-	X	-	-	-	X
HE21NL	X	-	-	X	-	-	-	-	X
HE21SL	X	-	-	X	-	-	-	-	X
HE21W	X	-	-	-	X	-	-	-	X
HE21WL	X	-	-	X	-	-	-	-	X
HE22K	-	X	-	-	X	-	-	-	X
HE22KL	-	X	-	X	-	-	-	-	X
HE22N	-	X	-	-	X	-	-	-	X
HE22NL	-	X	-	X	-	-	-	-	X
HE22W	-	X	-	-	X	-	-	-	X
HE22WL	-	X	-	X	-	-	-	-	X
HC20K	X	-	-	-	X	-	-	-	X
HC20KL	X	-	-	X	-	-	-	-	X
HC21K	X	-	-	-	X	-	-	-	X
HC21KL	X	-	-	X	-	-	-	-	X
HC22K	-	X	-	-	X	-	-	-	X
HC22KL	-	X	-	X	-	-	-	-	X
HC8021K	X	-	-	-	X	-	-	-	X
HP21KL	X	-	-	X	-	-	-	-	X
HP21NL	X	-	-	X	-	-	-	-	X
HP21SL	X	-	-	X	-	-	-	-	X
HP21WL	X	-	-	X	-	-	-	-	X
HP22KL	-	X	-	X	-	-	-	-	X
HP22NL	-	X	-	X	-	-	-	-	X
HP22WL	-	X	-	X	-	-	-	-	X

4.2 Combination with other products

REF MK-dent Turbine	HB21K/KL, HB23K/KL, HE20K/KL, HE21K/KL, HE22K/KL, HC20K/KL, HC21K/KL, HC22K/KL, HC8021K, HP21KL, HP22KL	HE21SL, HP21SL	HE21W/WL, HE22W/WL, HP21WL, HP22WL	HE21N/NL, HE22N/NL, HP21NL, HP22NL
REF MK-dent Coupling	QC4012K QC4014K QC5015K QC5016K QC5016KW QC5116K QC5116KW QC6016K QC6016KW QC6116K QC6116KW	QC5016SW QC6016SW	QC4014W QC5016W	QC4014NT QC5016NT QC6016NT
Connection	KaVo	Sirona	W&H	NSK

KaVo, Sirona, W&H and NSK are registered trademarks. MK-dent does not have any economical connection to the companies mentioned above.

4.3 Product components

Not applicable

4.4 Scope of delivery

The scope of delivery of the following components and accessories is part of the delivery unit:

HB12, HB14, HB15L, HB16L, HE11, HE12, HE14, HE15L, HE16L, HE17, HE17B, HE18			
AC0001	AC0003	LT1014P	--
Nozzle pin	Dental brush for maintenance of the spindle	Oil adapter for maintenance of the spindle	--

HB21K/KL, HB23K/KL, HE20K/KL, HE21K/KL, HE22K/KL, HC20K/KL, HC21K/KL, HC22K/KL, HC8021K, HP21KL, HP22KL			
AC0001	AC0003	LT1014P	LT1012P
Nozzle pin	Dental brush for maintenance of the spindle	Oil adapter for maintenance of the spindle	Oil adapter for maintenance of the rotor (KaVo)

HE21SL, HP21SL			
AC0001	AC0003	LT1014P	LT1017
Nozzle pin	Dental brush for maintenance of the spindle	Oil adapter for maintenance of the spindle	Oil adapter for maintenance of the rotor (Sirona)

HE21W/WL, HE22W/WL, HP21WL, HP22WL			
AC0001	AC0003	LT1014P	LT1018
Nozzle pin	Dental brush for maintenance of the spindle	Oil adapter for maintenance of the spindle	Oil adapter for maintenance of the rotor (W&H)

HE21N/NL, HE22N/NL, HP21NL, HP22NL			
AC0001	AC0003	LT1014P	LT1020
Nozzle pin	Dental brush for maintenance of the spindle	Oil adapter for maintenance of the spindle	Oil adapter for maintenance of the rotor (NSK)

When you open the delivered package for the first time, be sure that the packaging seal is not broken and that all components are included in the delivery. If something should be missing, please contact your dealer directly.

4.5 Required materials that are not included

NOTICE

NOTICE

The scope of delivery does not include a coupling.

The scope of delivery does not include an instrument holder article no. RT2050.

The scope of delivery does not include a holding force measuring tool article no. RT1020.

The scope of delivery does not include MK-dent Premium Service Oil article no. LU1011.

4.6 Configurations

The turbines are configured as explained under **4.1 Description**, but the options for connection differ. The various connections are described below:

REF MK-dent Turbine	HB21K/KL, HB23K/KL, HE20K/KL, HE21K/KL, HE22K/KL, HC20K/KL, HC21K/KL, HC22K/KL, HC8021K, HP21KL, HP22KL	HE21SL, HP21SL	HE21W/WL, HE22W/WL, HP21WL, HP22WL	HE21N/NL, HE22N/NL, HP21NL, HP22NL
Connection	KaVo	Sirona	W&H	NSK





KaVo, Sirona, W&H and NSK are registered trademarks. MK-dent does not have any economical connection to the companies mentioned above.





5 Accessories, tools, consumables and spare parts





5.1 Accessories

<p>Holding force measuring tool RT1020</p>	 A black handheld digital force gauge with a small LCD screen at the top. Below the screen are four buttons labeled 'UNIT', 'TARE', 'LIGHT', and 'ON/OFF'. The 'MK-dent' logo is printed in white on the lower part of the black housing. A silver metal probe is attached to the bottom.
<p>Instrument holder RT2050</p>	 A grey plastic instrument holder with a grid of 12 cylindrical slots of varying heights. The 'MK-dent' logo is printed in black on the front edge of the base.
<p>MK-dent Premium Service Oil LU1011</p>	 A blue aerosol can with a white nozzle. The label features the 'MK-DENT' logo at the top, followed by 'PREMIUM SERVICE OIL' in a white box. Below this are three line drawings of dental instruments. At the bottom of the label, it says 'LU1011 550', 'Volume = 500ml e', and 'NET 12.20 oz (345g)'.

5.2 Tools

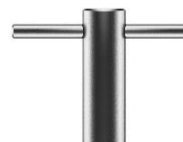
HB12, HB14, HB15L, HB16L, HE11, HE12, HE14, HE15L, HE16L, HE17, HE17B, HE18			
Key: KE1650T Assembly/Disassembly HB12, HB15L, HE11, HE12 HE15L, HE17B		Key: KE1651T Assembly/Disassembly HE17	
Key: KE1023T Assembly/Disassembly HB14, HB16L, HE14, HE16L, HE18		Torque wrench RT2025	

HB21K/KL, HB23K/KL, HE21K/KL, HE21N/NL, HE21SL, HE21W/WL, HE22K/KL, HE22N/NL, HE22W/WL			
Key: KE1650T Assembly/Disassembly HB21K/KL, HE21K/KL, HE21N/NL, HE21SL, HE21W/WL		Key: KE1024 Assembly/Disassembly HE21N/NL, HE22N/NL	
Key: KE1023T Assembly/Disassembly HB23K/KL, HE22K/KL, HE22N/NL, HE22W/WL		Torque wrench RT2025	

HE20K/KL, HC20K/KL, HC21K/KL, HC22K/KL, HC8021K, HP21KL, HP21NL, HP21SL, HP21WL, HP22KL, HP22WL, HP22NL			
Key: KE1651T Assembly/Disassembly HE20K/KL, HC20K/KL, HC21K/KL, HC8021K, HP21KL, HP21NL, HP21SL, HP21WL		Key: KE1024 Assembly/Disassembly HP21NL, HP22NL	
Key: KE1922 Assembly/Disassembly HE20K/KL, HC20K/KL, HC21K/KL, HC8021K, HP21KL, HP21SL, HP21WL		Torque wrench RT2025	
Key: KE1023T Assembly/Disassembly HC22K/KL, HP22KL, HP22NL, HP22WL			

5.3 Consumables

Not applicable

5.4 Spare parts



CAUTION

Use of unapproved accessories or making impermissible modifications on the product can result in injuries or malfunctions of the instrument.

→ Combine the product only with spare parts and components that are approved by MK-dent.

	Turbine with direct connection
Eco Line replacement turbine	Standard head: HE11, HE12, HE15L, HE17, HE17B Small head: HE18 Mini head: HE14, HE16L
Basic Line replacement turbine	Standard head: HB12, HB15L Mini head: HB14, HB16L

	Turbine with coupling connection
Prime Line replacement turbine	Standard head: HC8021K, HP21KL/NL/SL/WL Small head: HP22KL/NL/WL
Classic Line replacement turbine	Standard head: HC20K/KL, HC21K/KL Small head: HC22K/KL
Eco Line replacement turbine	Standard head: HE20K/KL, HE21K/N/W, HE21KL/NL/SL/WL Small head: HE22K/N/W, HE22KL/NL/WL
Basic Line replacement turbine	Standard head: HB21K/KL Mini head: HB23K/KL

6 Installation

6.1 Requirements for the environment

To supply the products with clean and dry air, clean the compressor air filter in your dental office. Do not lead in any moist compressed air. Please read the instruction manual of your air compressor for draining water from your compressor and for its regular maintenance. Be sure that the compressor is serviced according to its operating manual.

6.2 Unpacking

When opening the package for the first time, confirm that the content according to **4.4 Scope of delivery** is enclosed with the product. Make sure that the turbine has no defects or damages.

6.3 Assembly

Not applicable

6.4 Preparation for use



WARNING

Danger of infection for patients and users due to unsterile instruments

→ Before initial use and after each treatment, the instrument and accessories must be processed according to this Instruction Manual (see Chapter 8 **Reprocessing according to ISO 17664-1**).

Malfunction and/or danger of infection from moist, contaminated compressed air and contaminated water for cooling

→ The product may be used exclusively in the field of dentistry with a dental treatment unit, which has a CE-marking or is otherwise certified/approved according to the valid national legal regulations, and which is provided with an appropriate water and compressed air supply in compliance with the applicable standards.



CAUTION

A damaged instrument or damaged components can injure the patient, the user and third parties.

→ Test for proper functioning before each use and inspect the instrument visually for external damages.

→ Do not use the instrument and components if there are any irregularities.

If an air turbine is removed, water and oil will stay behind on the coupling connection. Remove the water and oil completely. Confirm that no water or oil is left behind in the coupling of your turbine hose. If there are still any residues left, remove them with a dry cloth.

Be sure that there are no water or oil residues left in the connection of the instrument. Remove residues with a cotton swab.

6.4.1 Check and setting of the compressed air



WARNING

Too high or too low compressed air compromises the performance of the instrument and can cause pain in the patient. In addition, problems during the use can also be caused, e.g. injuries due to instrument damages.

Connect a manometer to the coupling on your turbine hose and listen for the locking sound. Be sure that the measuring device is firmly attached. If you do not have a manometer, please contact your dealer.

Connect the instrument to the coupling of the manometer and listen for the locking sound. Confirm that the measuring device is firmly attached.

Check the following pressures (also see Chapter 13 **Technical data**):

- Drive air pressure
- Spray water pressure
- Spray air pressure
- Return air pressure

The compressed air must be set according to Chapter 13 **Technical data**. Remove the manometer after the pressure is set.

6.4.2 Connection to the coupling system



WARNING

**Malfunction caused by decoupling the instrument during the treatment.
An instrument that has not interlocked correctly can come loose from the hose coupling during the treatment.**

→ Pull on the instrument to check before each treatment if it sits firmly on the hose coupling.

Damages from inexact coupling.

Inexact coupling can destroy the high-pressure lamp or LED of the coupling or shorten its usage life.

→ Pull on the turbine to check whether it is firmly secured on the hose.

6.4.2.1 Connecting the instrument – Turbine with direct connection

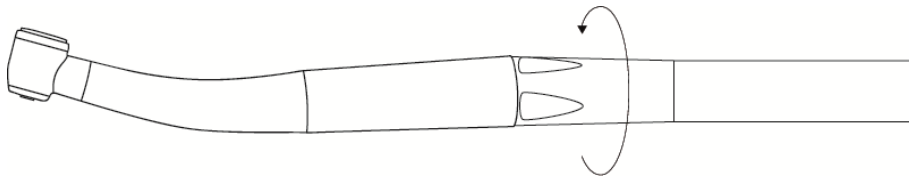

- Place the instrument exactly onto the hose connection and turn the hose sleeve in the direction of the arrow until the instrument sits firmly.
- Pull on the instrument to check whether it is firmly secure on the hose.
- To remove it, hold the instrument and turn the hose sleeve in the opposite direction of the arrow.

6.4.2.2 Connecting the instrument – Turbine with coupling connection



- Place the instrument exactly onto the coupling and press it down firmly until you can hear the connection snap in.
- Pull on the instrument to check whether it is firmly secure on the coupling.
- To remove it, hold the instrument and pull it off by turning it carefully.

6.5 Putting into service and operation

6.5.1 Before use

NOTICE

NOTICE

Before the start of every working day, the systems conducting water must be flushed for at least two minutes without any instruments attached. Another flushing process must be performed for 20 to 30 seconds after each patient, especially in case of products with return flow/reverse suction.

6.5.2 Check of correct operation



WARNING

Check the safe connection to the turbine hose after you have heard an interlocking sound. An instable connection leads to injuries caused by the instrument and other parts falling off.

Check that there are no damages, cracks, ruptures or any corrosion on the product and that it is safe to use.

If you encounter any problems, please read Chapter **11 Troubleshooting**. To set the water supply, use the water volume regulator of your treatment unit.

6.5.3 Testing the water quantity



WARNING

Injury to the pulp and tooth.

A low quantity of spray water can result in the overheating of the instrument and corresponding injuries.

→ Set the water quantity for the cooling water to min. 50 ml/min.

Check the water quantity with a measuring cup. Check the spray water tubes. If the water output is too low or a nozzle is clogged, clean the spray nozzle with the enclosed nozzle needle. Also see **8.1.2 Manual pre-cleaning of the spray nozzle**.

6.5.4 Insertion of rotating instruments



WARNING

Danger of injury to patients caused by the instrument falling out.

→ After each use of rotating instruments, check the holding force of the collet by pulling on the rotating instrument. Please ensure that this is done while the actuator is stopped.

Danger of injury to patients caused by damages on the instrument. Use of rotating instruments other than those listed below.

→ Use only rotating instruments with specifications that are equivalent of the data listed below.

→ Observe the Instruction Manual and intended use of the rotating instruments.



WARNING

Risk of injury from use of worn-out rotating instruments. Rotating instruments can fall out during the treatment and injure the patient.

→ Do not use any rotating instruments with worn-out shafts.

Risk of injury to users from rotating instruments. Cuts and potential infections can be caused as a result.

→ Use gloves or finger guards.

NOTICE

NOTICE

Use only rotating instruments made of steel or tungsten carbide, which comply with DIN EN ISO 1797 (type 3) and meet the following criteria:

Diameter of the shaft:	1.590 to 1.600 mm
Full insert length of the shaft (standard head/small head/mini head):	min. 12/11/9 mm
Length of the shaft (standard head/small head/mini head):	max. 21/21/19 mm
Diameter of the cutter:	max. 2 mm

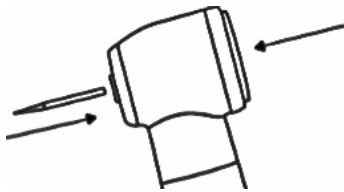

→ Press the button firmly with your thumb and simultaneously insert the rotating instrument until it stops.

→ Pull on the drill to check that it sits firmly.

→ Check the holding force of the collet at least once a week, using the RT1020 MK-dent dynamometer or another suitable device according to ISO 8325. The holding force of the collet must not fall below 2.5 kg. MK-dent recommends replacing the rotor when the holding force is below 3 kg.

7 Treatment

7.1 Patient, operator and assistant protection



WARNING

The product must be processed correctly before bringing it into contact with the patient the first time in order to prevent infection. See Chapter 8 Processing about this.

Protect the patient appropriately before use.

During the treatment, the user and assistants must wear gloves, safety goggles and masks to prevent infections.



CAUTION

Stop working in all cases whenever operating noises get louder or irregular, or there are stronger vibrations, or in any case of overheating or visual damages. In these cases, contact a repair workshop authorised by the manufacturer or your dealer.

MK-dent recommends lubricating the instrument after a treatment duration of 30 minutes, using the MK-dent Premium Service Oil; see Chapter 8.3.3 Maintenance, checks and testing. If the instrument is to be used again directly after it is lubricated, it must run in idle for 15–20 seconds to remove excess oil. If the instrument is to be used again later on the same patient, retain it in an instrument holder (Art. no. RT2050) so that any excess oil can drain.

7.2 Removing rotating instruments



WARNING

Risk of injury from rotating instruments. Cuts and damages on the clamping system.

- Never touch rotating instruments.
- Never use the push button while the instrument is rotating.
- Remove the rotating instrument after each treatment to prevent injuries and infections when putting it down.

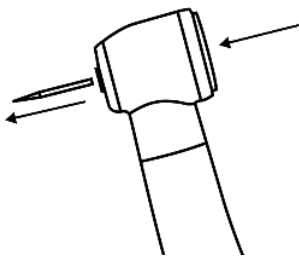

- Use your thumb to press the button firmly after the rotating instrument has come to a complete stop and pull it out at the same time.

8 Reprocessing according to ISO 17664-1

NOTICE

NOTICE

The lifecycle of the medical device is validated for 250 reprocessing cycles. After 250 reprocessing cycles, no significant negative effect on the product condition from processing could be detected. The possible number of applications does not depend on the processing cycles but rather on the application of the device and the wear and tear caused by this. The product lifetime is therefore determined by signs of wear and tear and damages that occur during use.

Dispose of damaged products according to Chapter **10 Disposal**. Do not use products with visible signs of wear and tear or damages.

Use only cleaning agents/disinfectants that are approved for the processing of medical devices. Notice the manufacturer's instructions for the cleaning agents/disinfectants. If unsuitable cleaning agents or disinfectants are used, this can have negative effects on the instruments:

- Damage or corrosion
- Discolouration of the product
- Corrosion of metal parts
- Reduced lifetime

Notice the information of the cleaning agent/disinfectant manufacturer. Do not use any abrasive cleaning agents/disinfectants.

The manufacturer recommends only using cleaning agents/disinfectants compliant with EN ISO 15883-1 and -2 for automatic cleaning/disinfecting.

The instruments can be sterilised. Do not use any sterilization temperatures above 135°C.

Ultrasonic cleaning is not recommended for processing the instruments, as the ball bearings can be damaged and the product lifetime could be reduced by this.

8.1 Processing at the location of use



WARNING

Risk of infection from unsterilised instruments. Always wear protective gloves.



CAUTION

Using disinfecting baths and disinfectants containing chlorine can cause defects and malfunctions of the instrument.

The cleaning result is diminished by surface-drying of residues.

→ Flush the transfer instrument immediately when you finish working on the patient

→ Immediately remove any cement, blood or composite residues

Do not submerge the instrument in solutions or similar.

NOTICE**NOTICE**

Clean the coupling on your turbine hose and on the inside of the instrument connector according to **6.4 Preparation for use** before reconnecting the instrument.

- Flush the inner tubes of the product according to the RKI specifications for 20 seconds while it is still connected to the treatment unit.
- The instruments should be pre-cleaned directly after the treatment in consideration of personal safety. The aim is to prevent organic material and chemical residues from drying in the lumen or on the outer parts of the instruments and to avoid contaminating the environment.
- Remove adhering dirt, body fluids and tissue using a disposable cloth/paper tissue.
- Flush the product with water after use (temperature below 35°C).
- Do not use any abrasive cleaning agents or water with temperatures above 35°C, as this can lead to increasing adhesion of the dirt and thereby complicate the further processing steps.
- Clean the instrument within one hour after each treatment to prevent surface drying.
- Ensure the instrument is stored safely and transported in dry condition in a closed container to the place of processing.

8.1.1 Preparation for cleaning

Take the drill out of the collet and pull off the instrument from the motor or quick-acting coupling. Take off all removable parts (if any) and wash each part under running water.

Manual pre-cleaning is also recommended for mechanical processing, such as to remove clogging in the spray tubes.

8.1.2 Manual pre-cleaning of the spray nozzle

**WARNING**

Injury to the pulp and tooth. A low quantity of spray water can result in the overheating of the instrument and corresponding injuries.

→ Check spray water tubes and, if necessary, clean the spray nozzles with the nozzle pin (AC0001) included in the delivery.

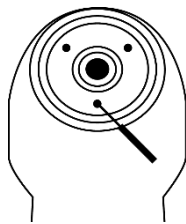

Carefully remove clogging in the spray tubes with the enclosed nozzle pin.

8.1.3 Manual pre-cleaning of the instrument



CAUTION

Insufficient cleaning of the surface and water and air tubes.

To ensure successful cleaning, it is necessary to perform thorough manual pre-cleaning. This also applies to the dental brush.

The application of manual pre-cleaning requires training of the employees who implement this processing instruction. This is necessary to ensure successful cleaning.

Tools:

- Drinking water¹ 30°C ± 5°C min. 100 ml
- Brush or soft toothbrush
- Dental brush (AC0003)
- 50 ml syringe or cannula
- Soft lint-free cloth



CAUTION

Risk of infection from dental brushes reused multiple times.

→ To avoid cross infection, use a new dental brush for each instrument to be cleaned.

Malfunctions can occur if cleaning is done in the ultrasonic machine.

→ Clean the instrument exclusively as described below.

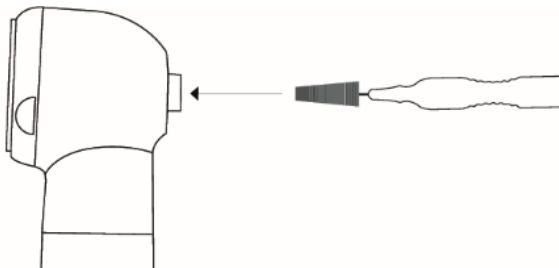

→ Carefully brush the complete instrument under running drinking water¹ using a brush or soft toothbrush to pre-clean the instrument.

→ To pre-clean the collet, insert the enclosed dental brush (AC0003) into the collet and carefully loosen/remove any deposits and dirt in rotating movements.

→ Repeat this process several times and flush the dental brush with drinking water¹ each time.

→ To pre-clean the water and air tubes, apply the syringe to the bottom end of the turbine and flush out the hollow spaces at least five times.

NOTICE

NOTICE

Repeat these steps several times in case of heavy dirt.

¹ Drinking water quality according to the EU Drinking Water Directive (total germ count max. 100 CfU/ml)

8.1.4 Manual pre-cleaning of the glass rod of turbines with light



CAUTION

Risk of scratching if not handled with care. Defects on the glass rod of the instrument.
→ Be extremely careful when you clean the glass rod.

Conduct a visual inspection after each cleaning of the glass rod. Do not use the turbine if the glass rod is damaged and contact your dealer or the MK-dent repair service.

Wash the visible part glass rod of the turbine with warm drinking water¹ using a soft lint-free cloth.
Dry it using a compressed air gun or do so carefully using a soft lint-free cloth.

8.2 Manual pre-cleaning

Tools:

- ALPRO® WL-clean cleaning solution
- ALPRO® WL-cid disinfectant solution
- ALPRO® WL-dry drying spray
- ALPRO® cleaning adapter depending on the connector
- Lint-free disposable cloth

NOTICE

NOTICE

Use alcohol-based instrument disinfectant with short residence time that does not cause any relevant adhesion of proteins on the instruments. The instrument disinfectant must be bactericidal, fungicidal and antiviral according to RKI requirements. Generally no disinfectants containing chlorine are to be used, as these can damage the handpieces. Do not use aldehydic disinfectants, as they are incompatible with the material. Generally only use disinfectants with microbiological efficacy confirmed or guaranteed by the manufacturer (e.g. VAH/DGHM registration or CE marking).

According to the RKI recommendation, thermal disinfection in a steam sterilizer must follow to the manual cleaning and disinfecting of medical devices of the “semi-critical B” class, especially if the instrument disinfectant used for the manual disinfection does not simultaneously have bactericidal, fungicidal and antiviral efficacy. Alternatively, the manual cleaning can serve as preparation for mechanical cleaning.

8.2.1 Manual cleaning

Connect the adapter to the Alpro® WL-clean spray bottle for cleaning the rotor and insert it into the turbine on the coupling side. Clean the instrument with 3 spray puffs for 2 seconds and with 1 minute resident time, respectively.

8.2.2 Manual disinfection, rinsing and drying

Disinfect the outer surfaces of the instrument using a disposable cloth drained with Alpro® WL-cid. Connect the adapter to the Alpro® WL-cid spray bottle for cleaning the rotor and insert it into the turbine on the coupling side and spray for 3 seconds. After 5 minutes of residence time, dry the instrument with Alpro® WL-dry spray.



CAUTION

The residence time after the last spray puff is 5 minutes.

8.3 Automatic cleaning

8.3.1 Cleaning, disinfection and rinsing

NOTICE



NOTICE

MK-dent recommends thermal disinfection devices that satisfy the requirements of EN ISO 15883-1 and are approved by the manufacturer for dental handpieces and turbines. The cleaning should be performed at min. 55°C for min. 6 minutes and disinfection at min. 90°C for min. 5 minutes (for AO value > 3000). A mildly alkaline cleaning agent with pH 9 to 11, e.g. Dr. Weigert Neodisher® MediClean Forte, is recommended.

The automatic cleaning and disinfection was validated using the device WD BHT INNOVA® M3 in program no. 03 thermal disinfection, with Dr. Weigert Neodisher® MediClean forte 0.5% as the cleaning agent. The instruments were connected with a silicon hose to a Luer-Lock adapter of the machine.

Parameters for automatic cleaning and disinfection:

- Pre-rinsing for 1 minute with Neodisher® MediClean forte 0.5% cleaning agent at 30°C
- Cleaning for 6 minutes with Neodisher® MediClean forte 0.5% cleaning agent at 55°C
- Rinsing for 1 minute with demineralised water
- Thermal disinfection for 5 minutes with demineralised water at 90°C (for an AO value > 3,000).

NOTICE

NOTICE

The final rinsing water must have drinking water quality according to the EU Drinking Water Regulation (total germ count max. 100 CfU/ml).

If there is still a visible contamination after processing in the thermal disinfection device, the process must be repeated.

8.3.2 Mechanical drying

The drying process is normally part of the cleaning process of your thermal disinfection device. Please follow the instructions for your thermal disinfection device.

To avoid any kind of interference with the instrument, ensure after each cycle that the instrument is dry on the inside and outside. If moisture remains on or in the instrument after the cleaning process, dry it off again with a lint-free cloth. When doing so, also check the lumens of the instruments and dry them off again with medical compressed air.

8.3.3 Maintenance, checks and testing



CAUTION

Premature wear and tear and malfunctions from improper maintenance and care

- Reduced product lifetime
- Perform appropriate maintenance and care at regular intervals

NOTICE

NOTICE

The instrument requires maintenance after each processing and before each sterilization. Use the MK-dent Premium Service Oil LU1011 for this purpose.

The instrument requires maintenance after each processing and before each sterilization. Perform the following steps in the order indicated below:

- Screw the included LT1014P oil adapter for maintenance of the spindle onto the oil can. Spray into the spindle for 2 seconds.
- Screw the included oil adapter for maintenance of the rotor onto the oil can. Insert it into the instrument on the coupling side and spray oil into the drive air canal for 2 seconds.

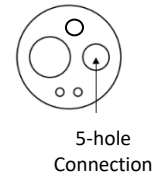
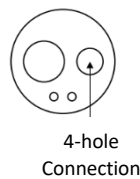
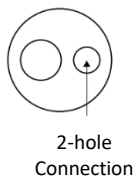

8.4 Sterilization in an autoclave

8.4.1 Wrapping

NOTICE

NOTICE

The sterilization bag must be big enough for the instrument so that the packaging does not get stretched. The sterilization packaging must conform to EN ISO 11607-1 and be suitable for the sterilization process. Pack each instrument separately into a single sterilization bag and check the weld seam for tightness.

8.4.2 Sterilization in a steam sterilizer according to EN 13060 / EN ISO 17665-1



WARNING

Premature wear and tear and malfunctions from improper maintenance and care

→ Reduced product lifetime

→ Maintenance of the instrument with the MK-dent Premium Service Oil is required before each sterilization.

Contact corrosion from moisture can cause damages on the product.

→ Take the instrument out of the steam sterilizer directly after the sterilization cycle.

This medical device has a temperature resistance of max. 135°C.



CAUTION

Discolouration of the product may occur depending on the conditions for use of your sterilizer or your sterilization methods.

NOTICE**NOTICE**

The instructions of the sterilizer manufacturer for operation and the loading configuration should always be followed. If you sterilize several instruments in one sterilization cycle, ensure that the instruments cannot touch each other in order to allow the best possible penetration of the steam. Notice the information in the sterilizer manufacturer's instruction manual.

After sealing it in the sterilization bag, place the instrument onto a sterilization tray to avoid direct contact with the surface of the sterilizer's interior chamber and put it into the autoclave. MK-dent recommends using a sterilizer according to EN 13060, EN ISO 17665-1 or EN 285. Sterilization must be performed in packaging suitable for the sterilization process. The packaging should comply with EN ISO 11607-1 (e.g. paper/laminate film).

8.4.3 Sterilization parameters

Only apply the following sterilization parameters:

Autoclave with fractioned pre-vacuum for at least 4 minutes at min. 134°C.

The sterilization was validated using the device W&H LISA 517, in a fractioned pre-vacuum process at 134°C for 4 minutes. According to the sterilizer manufacturer's instruction manual, the drying time for the sterilization process is calculated by the device software.

The instructions given above for processing a medical device for reuse have been validated and found to be suitable by the medical device manufacturer. The user is responsible for ensuring that the actually performed processing, including the devices and materials used in the processing system as well as the personnel, will render the intended result. This requires verification and/or validation, and routine monitoring of the process.

8.4.4 After sterilization

When the sterilization cycle is finished, take the instrument out of the autoclave. Notice here that the instruments are hot and be sure to use appropriate personal protective equipment for this purpose.

8.5 Storage

After sterilization and drying, check that there are no drops of residual water. Store the processed instruments in a dry, dark and cool room, protected from dust and with the lowest possible microbial load.

Temperature:	-20°C to +70°C (-4°F to +158°F)
Relative humidity:	5% to 95%, non-condensing
Air pressure:	700 hPa to 1060 hPa (10 psi to 15 psi)



CAUTION

Malfunction of the instrument during operation after heavily cooled storage conditions

→ Let heavily cooled instruments warm up to room temperature before starting to use them.

The instrument must be completely dried before storage. Remaining water can result in discolouration or rust.

Never store the instrument in a place where it could be exposed to water.

Do not store the instrument in places where chemicals are stored or where corrosive gases occur.

9 Maintenance

9.1 Regular maintenance and checks



WARNING

Improper maintenance or servicing can result in malfunctions and/or deterioration. Always conduct proper maintenance and servicing.



CAUTION

For safe use of the product, perform checks and maintenance of the instrument according to this Instruction manual.

9.2 Cleaning in case of problems

In case of problems with the air or water tubes, clean each part of the instrument. The instrument must be disconnected from the coupling for cleaning. You can find instructions in Chapter **6.4 Preparation for use**.

10 Disposal

Dispose of this instrument according to your local rules and regulations or clean the instrument according to chapter **8 Reprocessing** in this Instruction for use and return it to the manufacturer.

11 Troubleshooting

NOTICE

NOTICE

This instrument must never be repaired by the user in the event of a malfunction. Contact your dealer for repair.

If this instrument does not function as described in this manual, check the list below for your problem. If your problem is not resolved or if your problem is not listed below, please contact your dealer.

Symptoms	Possible causes	Countermeasures
1) Low efficiency	<ul style="list-style-type: none"> No air supply Compressed air is too low on the hose connection The control system of the treatment unit is not working 	<ul style="list-style-type: none"> Clean according to 8.2.1 Manual cleaning Set the motor pressure according to 13 Technical data Test the control unit with a different handpiece Request repair by your dealer
2) No water	<ul style="list-style-type: none"> The water supply system of your treatment unit is switched off No water gets into the turbine hose Water tubes are clogged 	<ul style="list-style-type: none"> Activate the water supply system of your treatment unit Check the water supply system of your treatment unit Request repair by your dealer
3) Water leak near the turbine hose	<ul style="list-style-type: none"> O-ring(s) on your connection is (are) damaged. 	<ul style="list-style-type: none"> Replace the seals Request repair by your dealer
4) No light	<ul style="list-style-type: none"> Light guide is defective Contact of the light guide is defective 	<ul style="list-style-type: none"> Replace the glass rod Repair/replace the connector Request repair by your dealer
5) Irregular operating noises	<ul style="list-style-type: none"> Ball bearing has run dry Rotor imbalance Ball bearing defective Corrugated spring disks are worn out O-rings are worn out 	<ul style="list-style-type: none"> Lubricate the turbine Replace the rotor Replace the corrugated spring disks Replace O-rings Request repair by your dealer
6) Strong vibrations	<ul style="list-style-type: none"> Ball bearing defective Ball bearing worn out 	<ul style="list-style-type: none"> Request repair by your dealer
7) Strong heat development	<ul style="list-style-type: none"> Rotor has run dry Insufficient water supply O-rings are worn out Ball bearing defective 	<ul style="list-style-type: none"> Lubricate/replace rotor Clean/replace the tube Replace O-rings Request repair by your dealer
8) Optical damages	<ul style="list-style-type: none"> Drop damage Deformation 	<ul style="list-style-type: none"> Replacement Request repair by your dealer
9) Rotation speed inadequate	<ul style="list-style-type: none"> Air supply insufficient 	<ul style="list-style-type: none"> Replace propellant air tube Cleaning Replace coupling Request repair by your dealer

12 Repair











Please ship the instrument to your dealer or directly to the manufacturer in case of defects.

13 Technical data

Article no.	Connection	Coating	Drive air pressure [bar]	Spray water pressure [bar]	Spray air pressure [bar]	Return air pressure [bar]	Air consumption [Nl/min]	Recommended press-pn force [N]	Spray water consumption [ml/min]	Operating sound [dB(A)]	Idle rotation speed [min ⁻¹]
HB12	4-hole	Chrome	2.2–2.5	0.8–2.5	1.0–4.0	< 0.5	40	2–3	> 50	< 65	335,000
HB14	4-hole	Chrome	2.2–2.5	0.8–2.5	1.0–4.0	< 0.5	40	2–3	> 50	< 65	425,000
HB15L	5-hole	Chrome	2.2–2.5	0.8–2.5	1.0–4.0	< 0.5	40	2–3	> 50	< 65	335,000
HB16L	5-hole	Chrome	2.2–2.5	0.8–2.5	1.0–4.0	< 0.5	40	2–3	> 50	< 65	425,000
HB21K	KaVo	Chrome	2.8	0.8–2.5	1.0–4.0	< 0.5	40	2–3	> 50	< 65	360,000
HB21KL	KaVo	Chrome	2.8	0.8–2.5	1.0–4.0	< 0.5	40	2–3	> 50	< 65	360,000
HB23K	KaVo	Chrome	2.8	0.8–2.5	1.0–4.0	< 0.5	40	2–3	> 50	< 65	425,000
HB23KL	KaVo	Chrome	2.8	0.8–2.5	1.0–4.0	< 0.5	40	2–3	> 50	< 65	425,000
HE11	2-hole	Chrome	2.2–2.5	0.8–2.5	1.0–4.0	< 0.5	40	2–3	> 50	< 60	335,000
HE12	4-hole	Chrome	2.2–2.5	0.8–2.5	1.0–4.0	< 0.5	40	2–3	> 50	< 60	335,000
HE14	4-hole	Chrome	2.2–2.5	0.8–2.5	1.0–4.0	< 0.5	40	2–3	> 50	< 60	425,000
HE15L	5-hole	Chrome	2.2–2.5	0.8–2.5	1.0–4.0	< 0.5	40	2–3	> 50	< 60	335,000
HE16L	5-hole	Chrome	2.2–2.5	0.8–2.5	1.0–4.0	< 0.5	40	2–3	> 50	< 60	425,000
HE17	4-hole	Chrome	2.2–2.5	0.8–2.5	1.0–4.0	< 0.5	40	2–3	> 50	< 60	360,000
HE17B	2-hole	Chrome	2.2–2.5	0.8–2.5	1.0–4.0	< 0.5	40	2–3	> 50	< 60	360,000
HE18	4-hole	Chrome	2.2–2.5	0.8–2.5	1.0–4.0	< 0.5	40	2–3	> 50	< 60	450,000
HE20K	KaVo	Chrome	2.8	0.8–2.5	1.0–4.0	< 0.5	40	2–3	> 50	< 60	370,000
HE20KL	KaVo	Chrome	2.8	0.8–2.5	1.0–4.0	< 0.5	40	2–3	> 50	< 60	370,000
HE21K	KaVo	Chrome	2.8	0.8–2.5	1.0–4.0	< 0.5	40	2–3	> 50	< 62	360,000
HE21KL	KaVo	Chrome	2.8	0.8–2.5	1.0–4.0	< 0.5	40	2–3	> 50	< 62	360,000
HE21N	NSK	Chrome	2.8	0.8–2.5	1.0–4.0	< 0.5	40	2–3	> 50	< 62	360,000
HE21NL	NSK	Chrome	2.8	0.8–2.5	1.0–4.0	< 0.5	40	2–3	> 50	< 62	360,000
HE21SL	Sirona	Chrome	2.7	0.8–2.5	1.0–4.0	< 0.5	40	2–3	> 50	< 62	360,000
HE21W	W&H	Chrome	3.0–3.3	0.8–2.5	1.0–4.0	< 0.5	40	2–3	> 50	< 62	370,000
HE21WL	W&H	Chrome	3.0–3.3	0.8–2.5	1.0–4.0	< 0.5	40	2–3	> 50	< 62	370,000
HE22K	KaVo	Chrome	2.8	0.8–2.5	1.0–4.0	< 0.5	40	2–3	> 50	< 62	440,000
HE22KL	KaVo	Chrome	2.8	0.8–2.5	1.0–4.0	< 0.5	40	2–3	> 50	< 62	440,000
HE22N	NSK	Chrome	2.8	0.8–2.5	1.0–4.0	< 0.5	40	2–3	> 50	< 62	440,000
HE22NL	NSK	Chrome	2.8	0.8–2.5	1.0–4.0	< 0.5	40	2–3	> 50	< 62	440,000
HE22W	W&H	Chrome	3.0–3.3	0.8–2.5	1.0–4.0	< 0.5	40	2–3	> 50	< 62	475,000
HE22WL	W&H	Chrome	3.0–3.3	0.8–2.5	1.0–4.0	< 0.5	40	2–3	> 50	< 62	475,000
HC20K	KaVo	Chrome	2.8	0.8–2.5	1.0–4.0	< 0.5	40	2–3	> 50	< 57	370,000
HC20KL	KaVo	Chrome	2.8	0.8–2.5	1.0–4.0	< 0.5	40	2–3	> 50	< 57	370,000
HC21K	KaVo	Chrome	2.8	0.8–2.5	1.0–4.0	< 0.5	40	2–3	> 50	< 57	360,000
HC21KL	KaVo	Chrome	2.8	0.8–2.5	1.0–4.0	< 0.5	40	2–3	> 50	< 57	360,000
HC22K	KaVo	Chrome	2.8	0.8–2.5	1.0–4.0	< 0.5	40	2–3	> 50	< 60	440,000
HC22KL	KaVo	Chrome	2.8	0.8–2.5	1.0–4.0	< 0.5	40	2–3	> 50	< 60	440,000
HC8021K	KaVo	Titanium	2.8	0.8–2.5	1.0–4.0	< 0.5	40	2–3	> 50	< 60	360,000
HP21KL	KaVo	Titanium	2.8	0.8–2.5	1.0–4.0	< 0.5	40	2–3	> 50	< 55	360,000
HP21NL	NSK	Titanium	2.8	0.8–2.5	1.0–4.0	< 0.5	40	2–3	> 50	< 55	360,000
HP21SL	Sirona	Titanium	2.7	0.8–2.5	1.0–4.0	< 0.5	40	2–3	> 50	< 55	360,000
HP21WL	W&H	Titanium	3.0–3.3	0.8–2.5	1.0–4.0	< 0.5	40	2–3	> 50	< 55	370,000
HP22KL	KaVo	Titanium	2.8	0.8–2.5	1.0–4.0	< 0.5	40	2–3	> 50	< 55	440,000
HP22NL	NSK	Titanium	2.8	0.8–2.5	1.0–4.0	< 0.5	40	2–3	> 50	< 60	440,000
HP22WL	W&H	Titanium	3.0–3.3	0.8–2.5	1.0–4.0	< 0.5	40	2–3	> 50	< 60	475,000

MK-dent recommends setting the spray air pressure min. 0.3 bar higher than the spray water pressure.

14 Explanation of symbols

	See Chapter 1 Explanation of warnings
	See Chapter 1 Explanation of warnings
	Product can be sterilised in a steam sterilizer (autoclave)
	Product can be used in thermal disinfectors for automatic cleaning
CE 0123	CE marking – Confirms that this product fulfils all applicable requirements with applicable EU legislation in force
	Reference number
	Serial number
	Legal manufacturer
	Date of manufacture
	Consult instructions for use
	Unique Device Identifier

15 Warranty

MK-dent provides the end consumer a warranty that is valid from purchase for correct functioning as well as defect-free material and workmanship. The invoice date is decisive for this.

The manufacturer additionally grants a full-service carefree guarantee valid in Germany for the Eco Line, Classic Line and Prime Line.

The following periods must be noted for this:

Designation	Germany		International
	Warranty	Full-service carefree guarantee	Warranty
Basic Line Turbine	12 months	-	12 months
Eco Line Turbine	24 months	12 months	18 months
Classic Line Turbine	24 months	18 months	18 months
Prime Line Turbine	24 months	24 months	24 months

In the event of justified complaints, MK-dent will perform repair free of charge or deliver a free replacement if necessary. This decision is at the discretion of MK-dent. Further claims of any kind, in particular for damage compensation are excluded. In the event of default, gross negligence or intent, this applies only insofar as no compulsory legal regulations apply.

MK-dent has no liability for occurred defects and their consequences, which can result from natural wear and tear, improper handling, improper cleaning or maintenance, failure to observe operating or other instructions, calcination or corrosion, contaminated air and water supply, or chemical or electrical influences that are extraordinary or impermissible according to the MK-dent Instruction Manual or other instructions of the manufacturer.

The warranty usually does not cover rubber parts and colour fastness of plastic parts.

Any liability is excluded for defects or their consequences resulting from any manipulation or modifications of the product by the end consumer or a third party not authorised by MK-dent.

Warranty claims will be accepted only if the product is returned with purchase receipt in the form of an invoice or a copy of the delivery slip. The name of the dealer, the purchase date, model and serial number must be clearly legible.